

Network Radio

TULS - N- 3, networking mobile units



Dimensions
 35 x 125 x 185 mm

KEY FEATURES

- frequency range 4.9- 5.8 GHz (other frequencies on request)
- 2x 250 mW output power
- antenna diversity mode
- RF bitrate up to 54 Mbps
- 10 to 36 Vdc isolated power supply
- wireless point-to-point and networking capabilities
- communication ports: RS232 and Ethernet 100Base-TX
- integrated tracking antenna control interface

Description:

The TULS - N network radio is a component in the heart of TWINS, the modular IP transmission system. Its main use is for networking mobile units, such as unmanned aircraft and a ground station, with the aim of achieving the highest data rate possible while also working over long ranges. The TULS takes the burden of wireless-related technical worries away from the user and provides an Ethernet connection at each station which makes the whole system working like a conventional WLAN. The preferred frequency ranges are 4.4 - 4.5 GHz and 4.9 - 5.8 GHz; however, the modular design makes it possible to have systems for any required frequency.

Use under actual conditions is made much easier by the integrated automatic antenna tracking feature that is always available for operation without manual adjustment. The information required by each station about geographical location and spatial orientation is supplied by GPS together with an electronic compass and accelerometers, even making an accurate horizontal orientation of the ground antenna unnecessary.

By using the wireless link, each unit knows the position of the other units and can control the direction of its own antenna. In addition, there is a protocol interface for accepting external attitude and position data; in the airborne system, for example, supplying the current values of roll, pitch and heading can improve the accuracy of the control. The ground system can also be used as a tracking system for other wireless systems if it is supplied with the appropriate target position.

Functionally, the TULS- N consists of the central processor unit, the RF section and various auxiliary and supply units.

Functional bloc diagram:

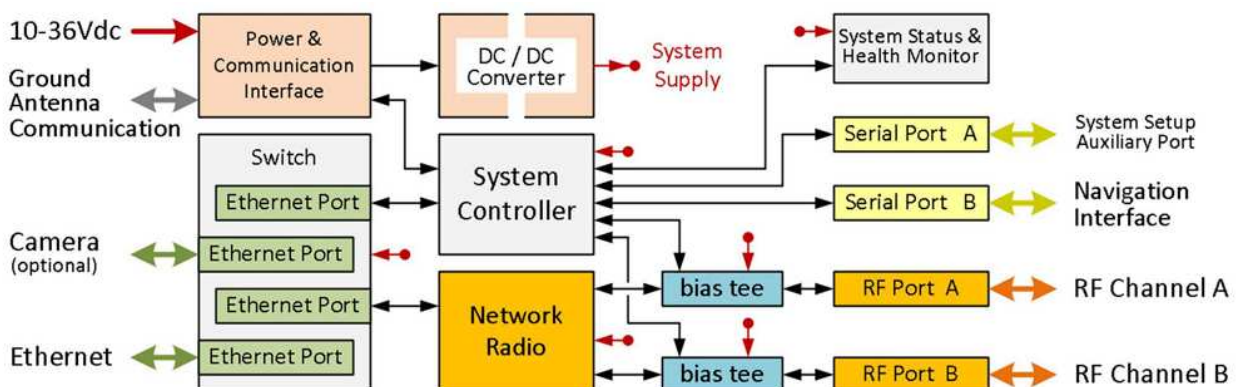

Specifications:

Model	TULS - N
Frequency Range	4.9 to 5.8 GHz other frequencies on request
Output Power	200 mW (programmable)
TX Channel Width Support	5/10/20/40 MHz
Modulation	OFDM (52 sub- carrier)
Data Rates	1.5 to 54 Mbps
OFDM long range mode	up to 3.2 μ s multipath distortion protection
Power Supply	10 to 36 Vdc (isolated)
Supply Current	0.6 A @ 12 V; 0.3 A @ 28 V
Supply Current with TULS - M Q	2.5 A peak @ 28 V
Temp. Range	- 30°C to + 80°C
Altitude	\leq 10000 m
Command/Control Protocol	TWINS
Humidity	\leq 95% RH
Vibration	10g (sine 20Hz- 2kHz)
Shock ($\frac{1}{2}$ sine)	100g peak (11ms)
Dimensions	35 mm (height) x 125 mm x 185 mm
Weight	1100 g

Outline drawing:

